

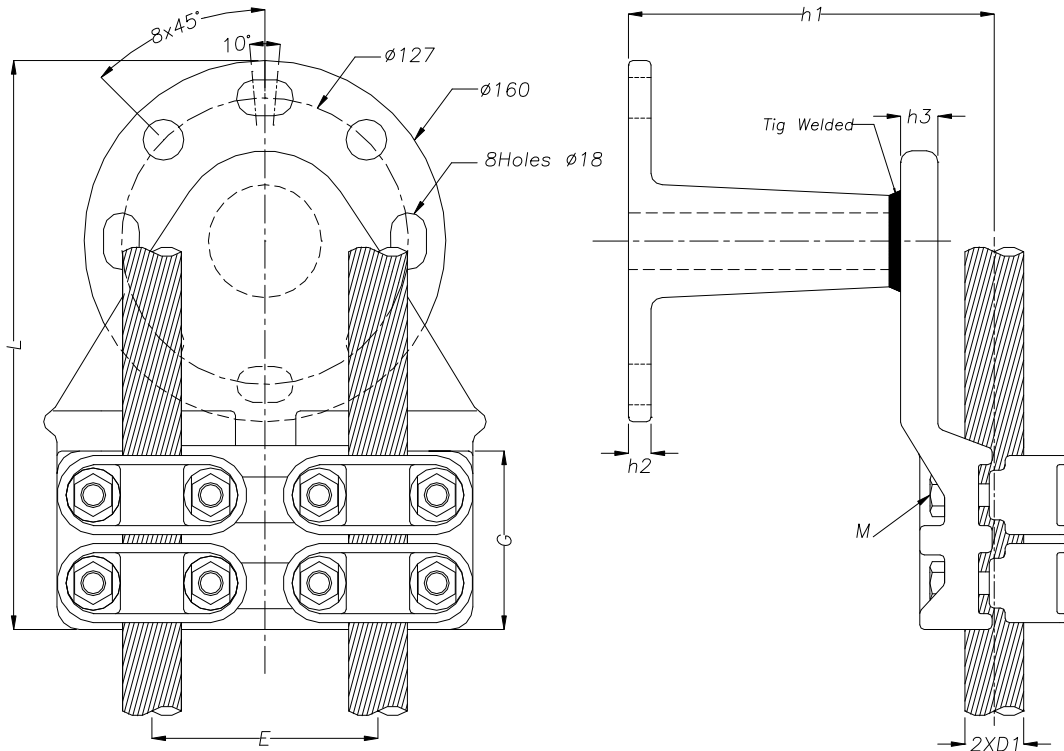

Twin Bundle Conductor to P.I.

PART No.	Dimensions in mm								Slide or Fix	Net Weight Kg / unit.
	$\Phi$ D1	G	h1	h2	h3	M	L	E		
<b>Fig. 1</b>										
CDB30F16		83	150	11	20	10	230	100		
CDB25F16		83	150	11	20	10	230	100		
CDB45F16		83	150	11	20	10	230	105		
CDB40F16		83	150	11	20	10	230	105		
CDB35F16		83	150	11	20	10	230	100		





Twin Bundle Conductor to P.I.-Vertical

PART No.	Dimensions in mm							Slide or Fix	Net Weight Kg / unit.
	$\Phi$ D1	G	h	M1	M2	L	E		
<b>Fig. 1</b>									
CDB35F16V		99	11	12	10	180	105		
CDB30F16V		99	11	12	10	182	105		
CDB45F16V		98	11	12	10	180	105		
CDB40F16V		102	11	12	10	188	105		

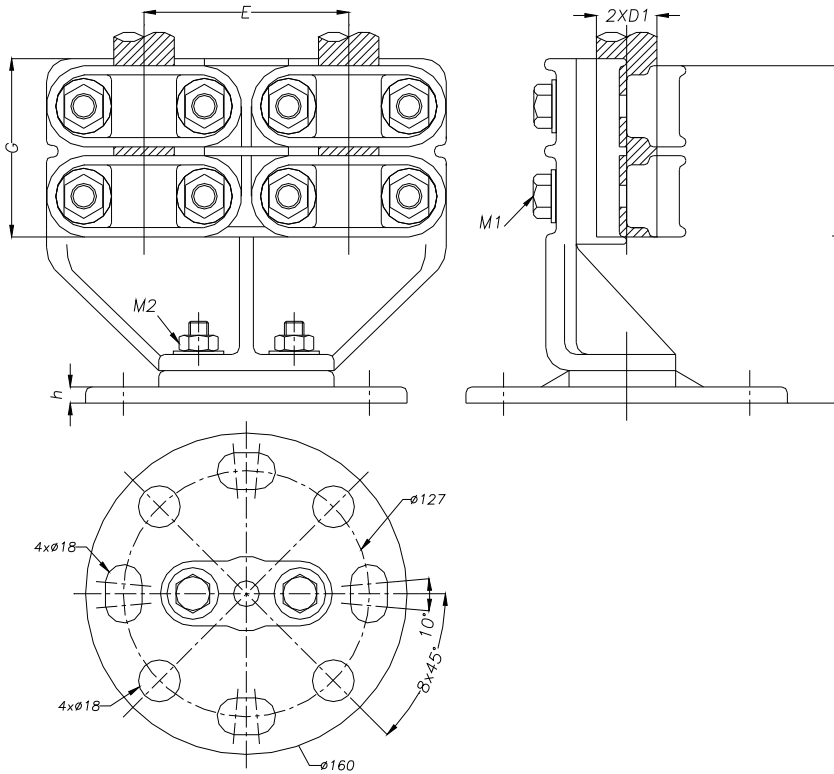



Twin Bundle Conductor to P.I.

PART No.	Dimensions in mm								Slide or Fix	Net Weight Kg / unit.
	$\Phi$ D1	G	h1	h2	h3	M	L	E		
<b>Fig. 1</b>										
CDB35F26		83	15	11	20	10	283	100		
CDB30F26		83	15	11	20	10	283	100		
CDB40F26		83	15	11	20	10	283	100		
CDB40F26/C		83	15	11	20	10	283	100		

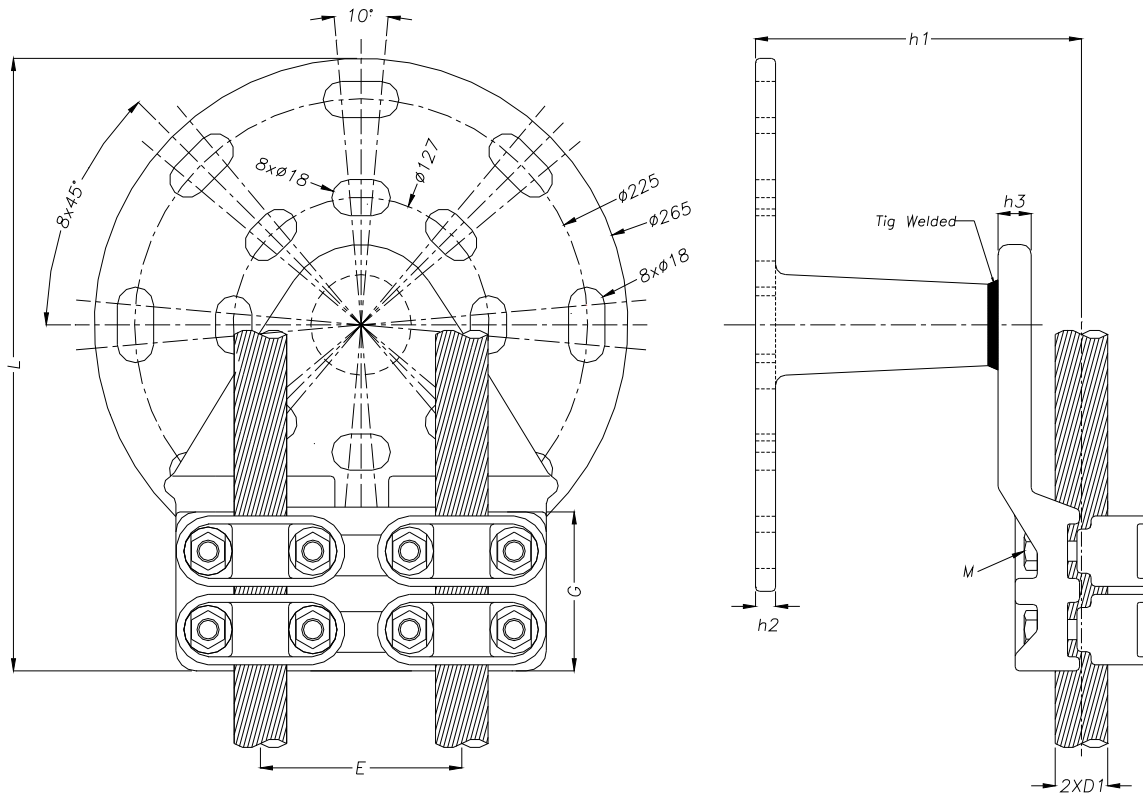



Twin Bundle Conductor to P.I.-Vertical

PART No.	Dimensions in mm							Slide or Fix	Net Weight Kg / unit.
	$\Phi$ D1	G	h	M1	M2	L	E		
<b>Fig. 1</b>									
CDB45F26V		98	14	12	10	190	105		
CDB40F26V		98	14	12	10	190	105		

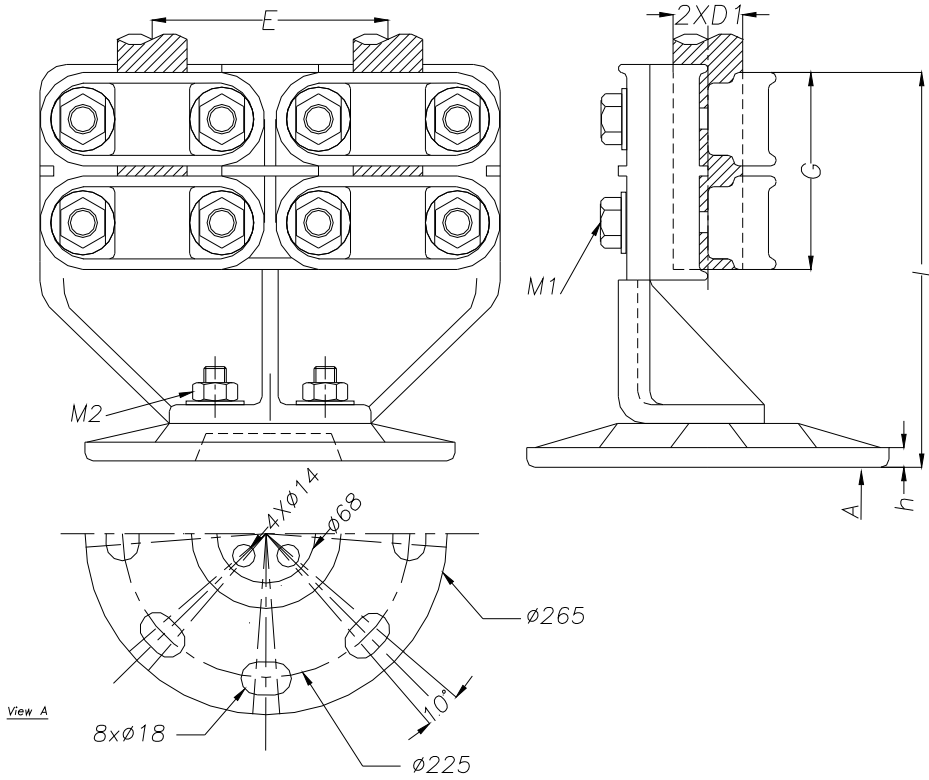



Twin Bundle Conductor to P.I.

PART No.	Dimensions in mm								Slide or Fix	Net Weight Kg / unit.
	$\Phi$ DI	G	h1	h2	h3	M	L	E		
<b>Fig. 1</b>										
EDB322F108		127	150	10		10	226	100		
EDB383F108		128	150	10		10	252	100		

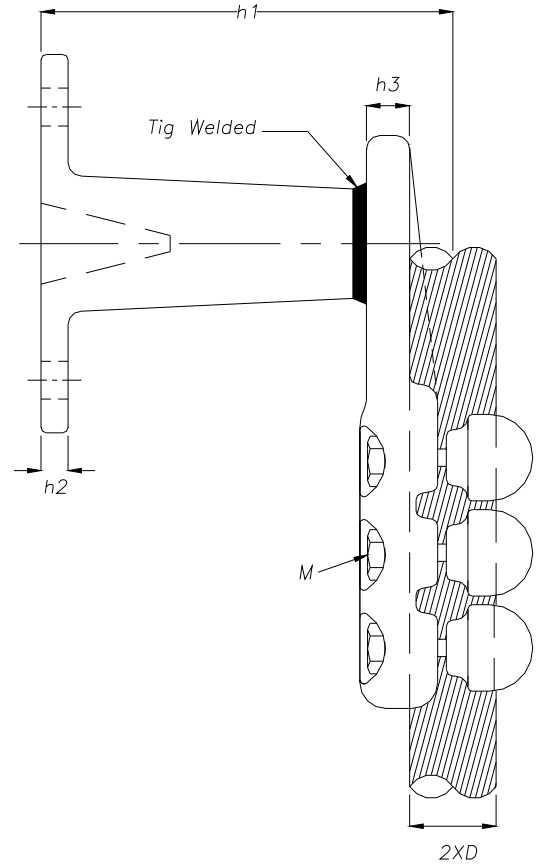
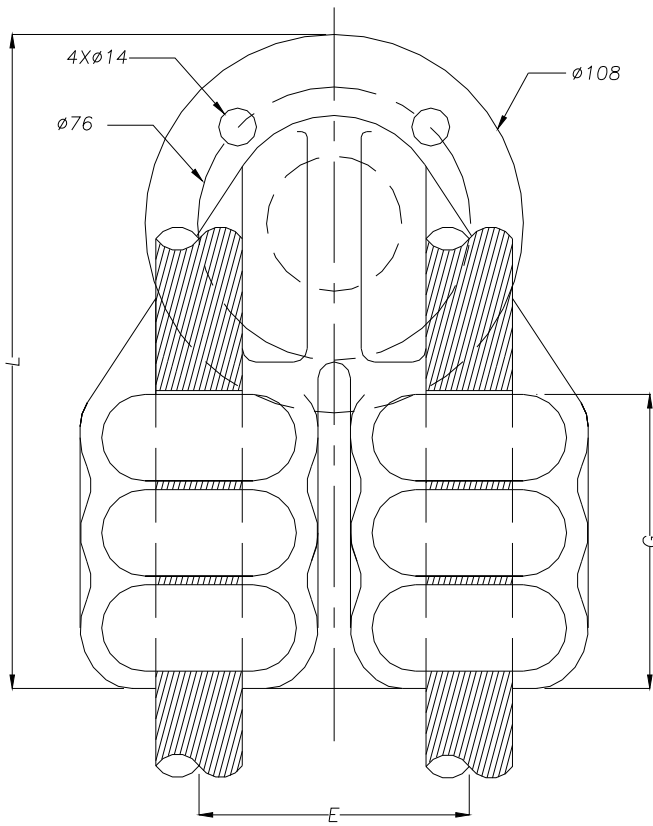



Twin Bundle Conductor to P.I.

PART No.	Dimensions in mm							Slide or Fix	Net Weight Kg / unit.
	$\Phi$ D1	G	h1	h2	M	L	E		
<b>Fig. 1</b>									
EDB383F108	36.2-38.3	128	150	10	10	252	100		
EDB322F102	30.1-32.2	128	150	10	10	226	100		

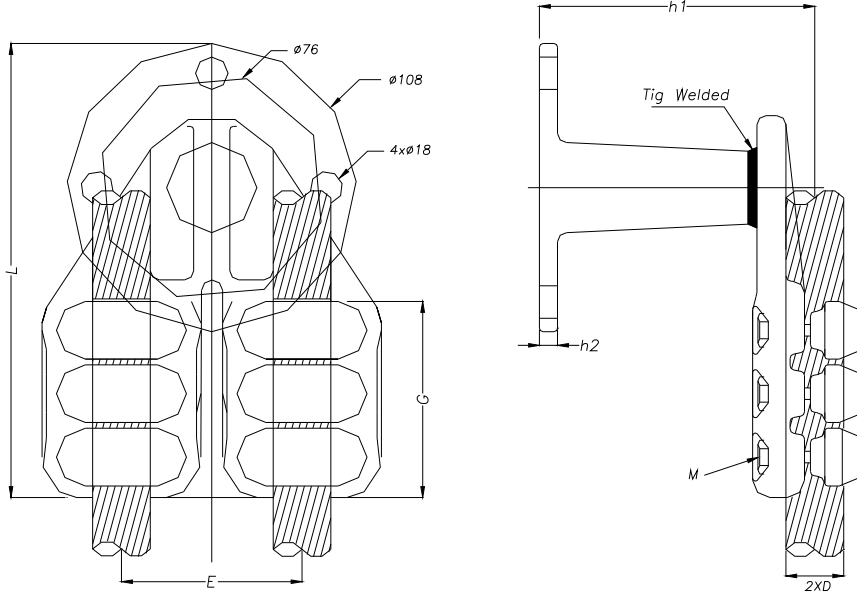



Twin Bundle Conductor to P.I.

PART No.	Dimensions in mm								Slide or Fix	Net Weight Kg / unit.
	$\Phi$ D1	G	h1	h2	h3	M	L	E		
<b>Fig. 1</b>										
EDB322F108		127	150	10		10	226	100		
EDB383F108		128	150	10		10	252	100		

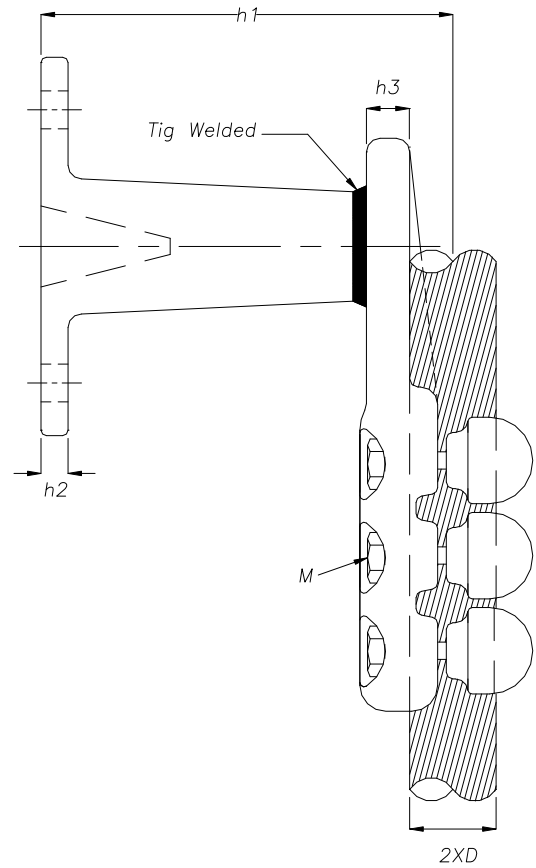
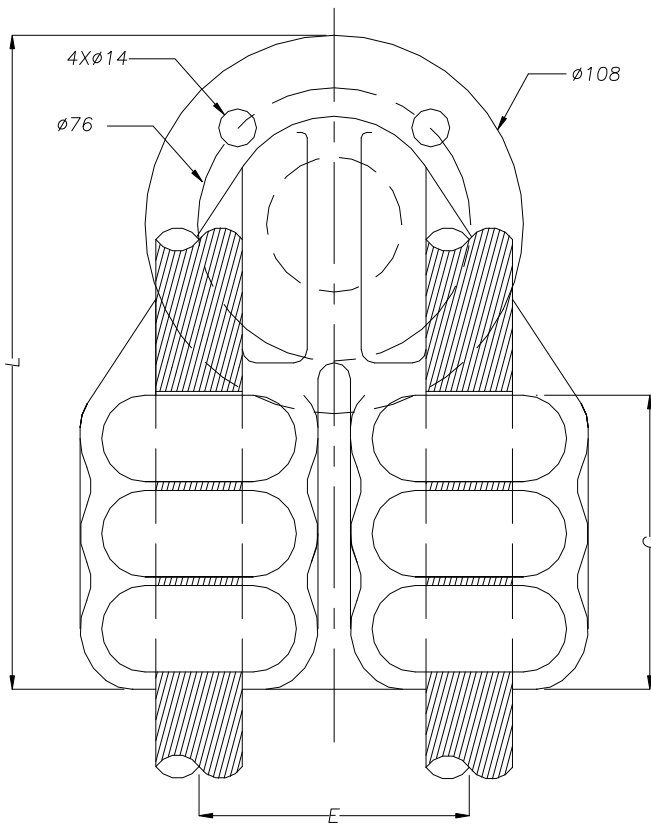



Twin Bundle Conductor to P.I.

PART No.	Dimensions in mm							Slide or Fix	Net Weight Kg / unit.
	$\Phi$ D1	G	h1	h2	M	L	E		
<b>Fig. 1</b>									
EDB383F108	36.2-38.3	128	150	10	10	252	100		
EDB322F102	30.1-32.2	128	150	10	10	226	100		

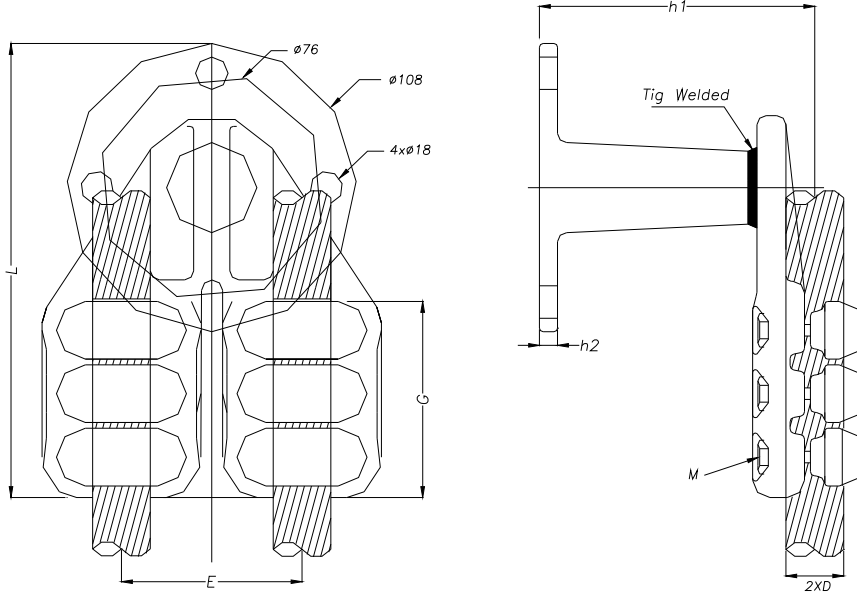



Twin Bundle Conductor to P.I.-Vertical

PART No.	Dimensions in mm						Slide or Fix	Net Weight Kg / unit.
	$\Phi$ D1	G	h1	h2	M	E		
<b>Fig. 1</b>								
EDB383F26V	36.2-38.3	120	195	14	10	100		

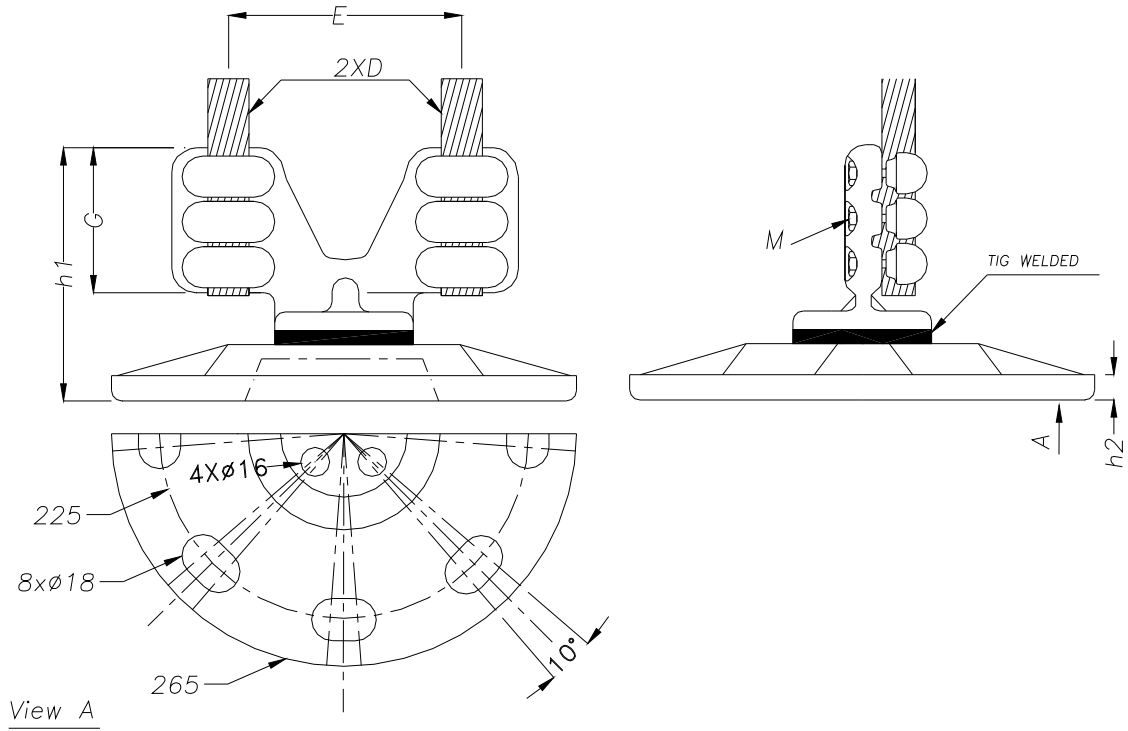



Twin Bundle Conductor to P.I.- Vertical

PART No.	Dimensions in mm						Slide or Fix	Net Weight Kg / unit.
	$\Phi$ D1	G	h1	h2	M	E		
<b>Fig. 1</b>								
EDY415F16V	40.1-41.5	120	196	13	10	200		
EDY383F16V	36.2-38.3	120	196	13	10	200		

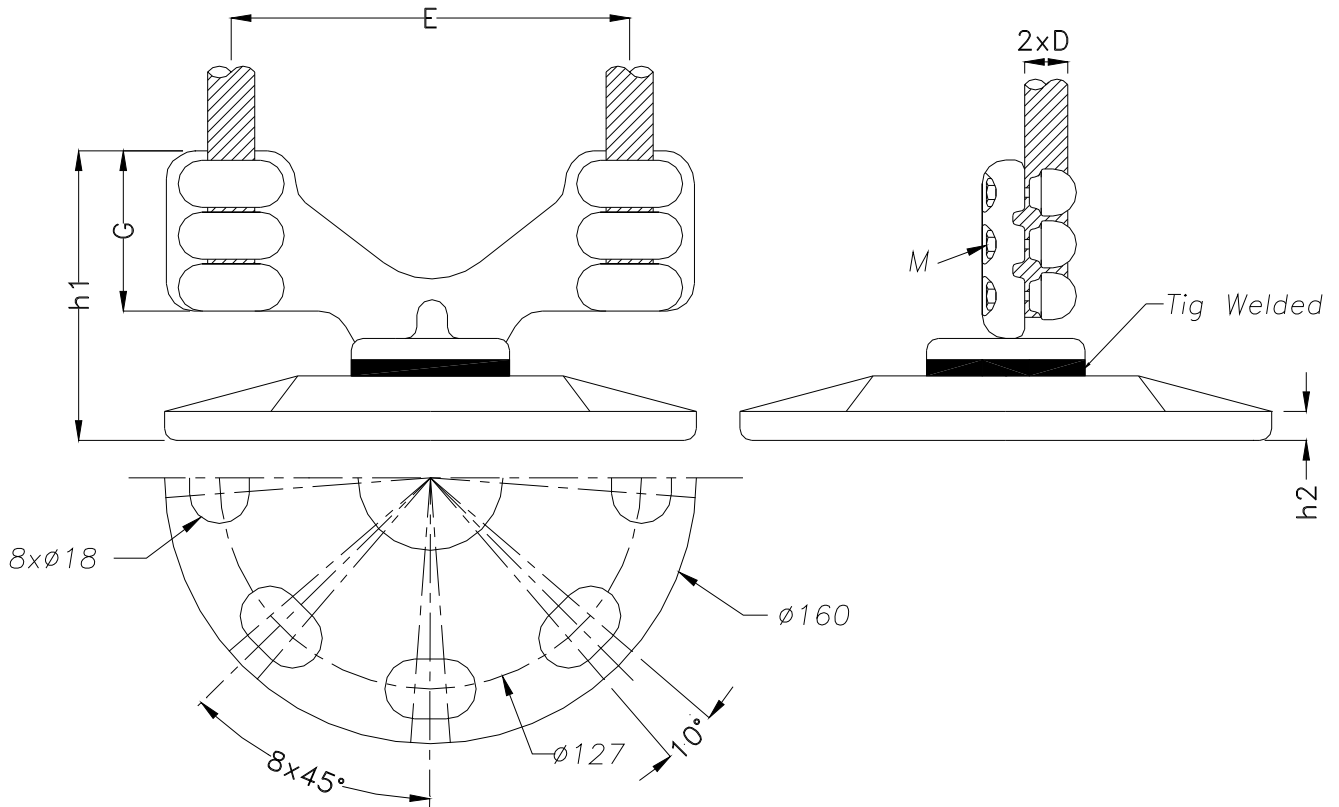



**Twin Bundle Conductor to P.I.-Vertical**

PART No.	Dimensions in mm						Slide or Fix	Net Weight Kg / unit.
	$\Phi$ D1	G	h1	h2	M	E		
<b>Fig. 1</b>								
EDY383F26V	36.2-38.3	120	195	14	10	200		
EDY335F26V	32.3-33.5	120	196	13	10	200		
EDY322F26V	30.1-32.2	120	196	13	10	200		
EDY300F26V	28.1-30.0	120	196	13	10	200		
EDY415F26V	40.1-41.5	120	196	13	10	200		

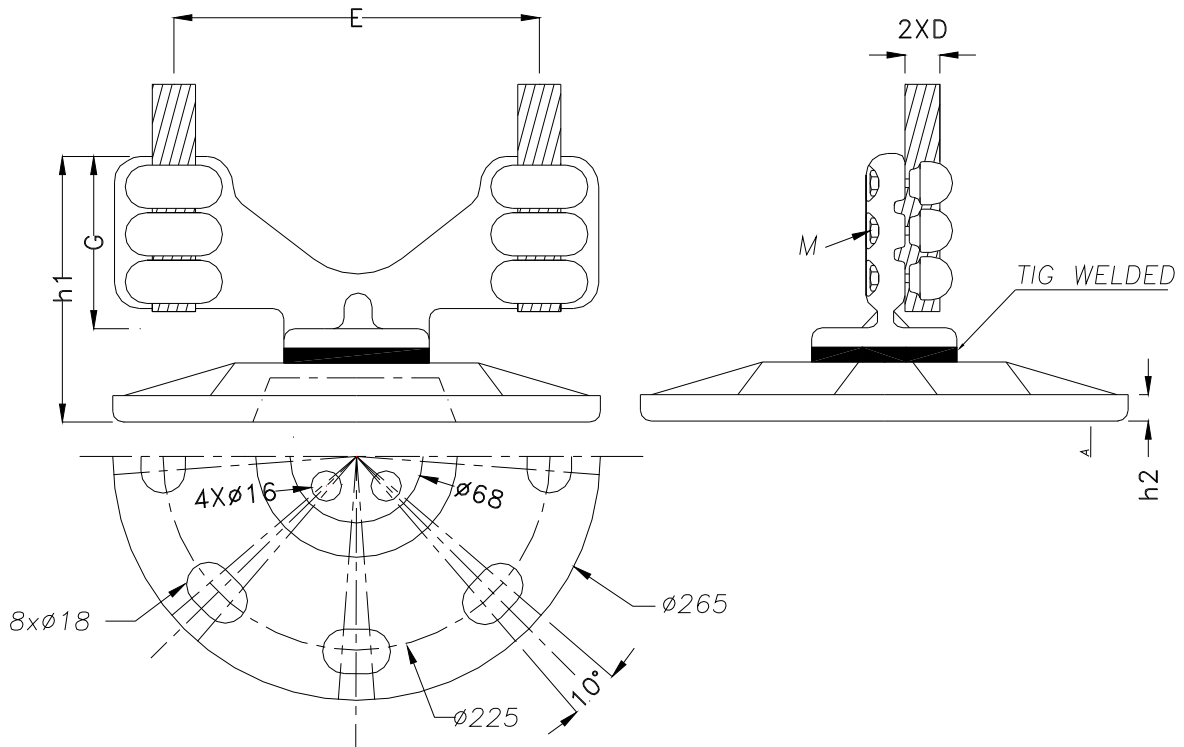



Tube to P.I.

PART No.	Dimensions in mm			Net Weight
	$\Phi$	G	M	Kg / unit.
	D			
C80F26V	80		12	
C100F26V	100		12	

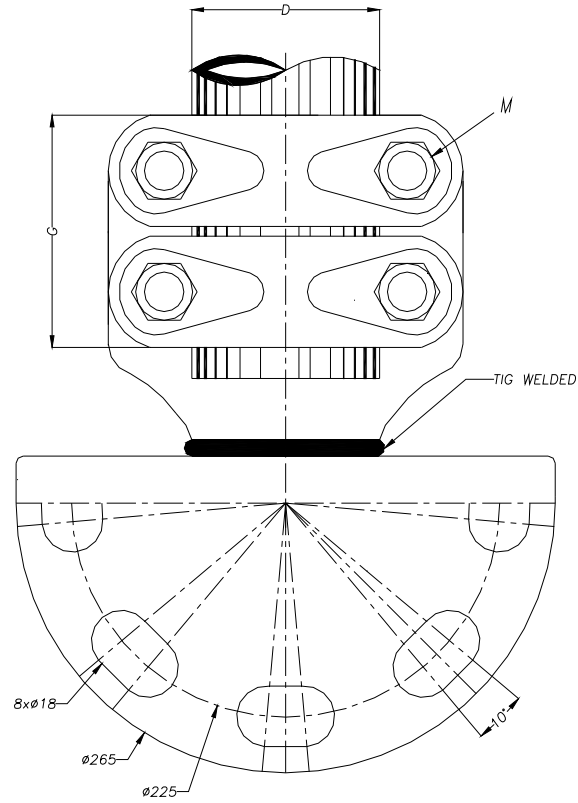



Bundle Conductor to P.I.- Vertical

PART No.	Dimensions in mm						Net Weight Kg / unit.
	$\Phi$ D	G	h1	h2	h3	M	
C40F16V	36-41	92	180	11	21.5	12	
C30F16V	26-31	92	180	11	21.5	12	
C45F16V	41-46	92	180	11	21.5	12	

