

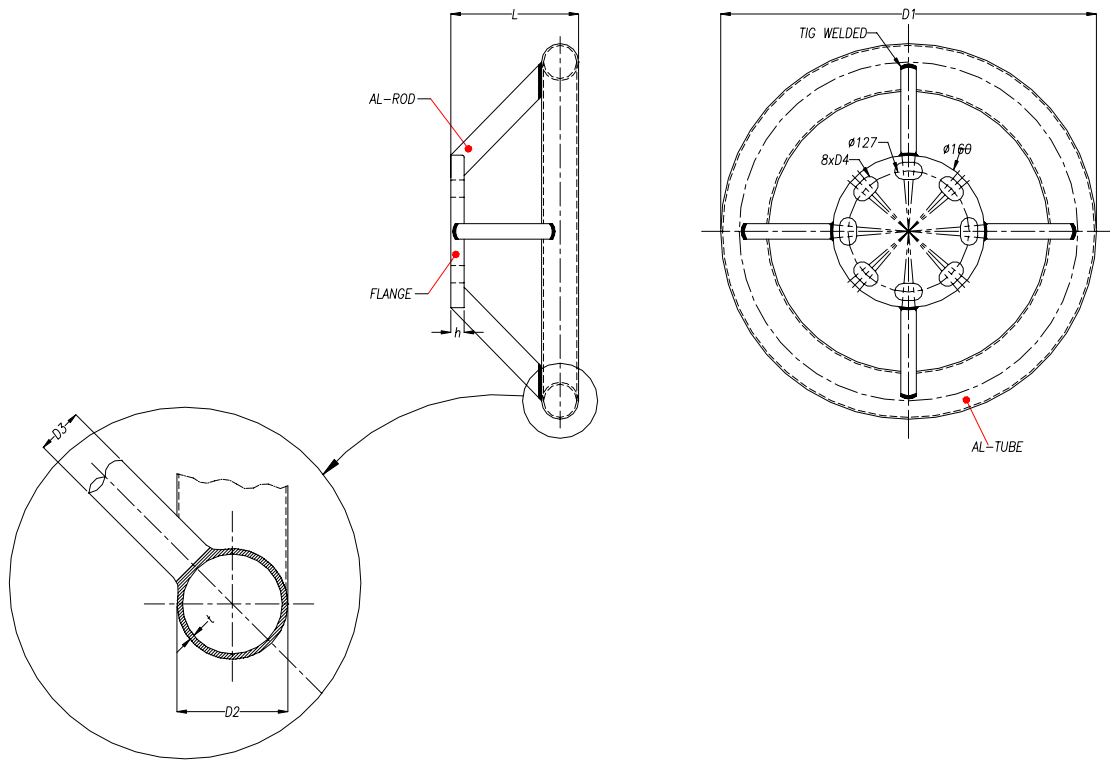

CORONA SHIELD RING

PART No.	Dimensions in mm							Net Weight Kg / unit.
	Φ				h	L	t	
	D1	D2	D3	D4				
AH.50.394-F16	394	50	25	18	14	134	3	
AH.50.385-F16	385	50	25	18	14	134	3	
AH.50.385-F16	385	51	25	18	14	134	2.5	
AH.50.350-F16	350	51	25	18	14	134	2.5	
AH.50.500-F16	500	51	25	18	14	134	2.5	
AH.50-394-F16	394	50	25	18	14	134	3	





CORONA SHIELD RING

PART No.	Dimensions in mm							Net Weight Kg / unit.
	Φ				h	L	t	
	D1	D2	D3	D4				
AH.50.740-F26	740	51	25	18	14	214	2.5	
AH.50.585-F26	585	50	25	18	14	134	3	
AH.50.500-F26	500	51	25	18	14	134	2.5	
AH.50.470-F26	470	50	25	18	14	134	3	
AH.50.570-F26	570	50	25	18	14	134	3	

